

New Beta

Monitoring and control IoT system ready to display real time information



Description

The modular and IoT focused New Beta device is designed for control, real-time, and remote monitoring of refrigeration systems with high safety and precision requirements. Adapted to your application, the system is ready and user-friendly after mounting. WEB supported, can be directly attached to an ordered Touchscreen or LED Panel HMI.

Features

Visualization

LED 4 digits Display; or LCD Display, Full HD, 4.3" Touch Screen, for visualization of:

- Up to 5 chosen variables measures, besides consumed electrical power.
- Alarm limits configuration, among other parameters.
- Active outputs.
- Battery level.
- AC connector.
- Wi-Fi or GPRS signal quality.
- Graphic record of each variable for the last 24 hours.

Alarms

- Inbuilt visual and sound alarms, as well as WEB and Application (APP) support.
- External alarms by SMS and e-mail.

Ordering Information

NB031801	Controller set for 3 analog sensors, 2 digital inputs. 5 control relay outputs. With in-built visual / sound alarms.
NB031802-LED01	LED panel with 7 segments / 4 digits Display, and several LED indicators.
NB031803-LCD43	LCD Display. Resolution 480 X 272. Touch. Full HD, 4.3"
NBSE031801	NTC sensor for New Beta (-40 to +50°C)
NBSE031802	Current Transformer. 2000:1
NBBC031801	Battery Charger 6V, 0.2 A
NB031803-Wi-Fi	Board for Wi-Fi (IEEE 802.11) 2.4 GHz. WPA2 encryption.
NB031803-GPRS	Board for GPRS. Quad Band: 850/ 900 /1800 /1900 MHz
NB031803-Sigfox	Board Sigfox Ready, RC2 902 – 905Mhz / RC4 920 - 923Mhz, 22dBm ERP

Contact Information

To reach New Beta manufacturer, refer to:

Mail: info@3sense.tech
 USA: +1 (786) 584-7439
 WhatsApp: +1 (786) 584-7439
 Visit: www.3sense.tech



GENERAL SPECIFICATIONS

ELECTRICAL RATINGS		
Parameter	Value	Units
Maximum Input Current	≤ 0.2	A
Maximum Input Voltage	≤ 270	VAC, 50/60 Hz
Rated Input Voltage	110 - 220	VAC, 50/60 Hz
Input Voltage Range	90 - 264	VAC, 50/60 Hz
Rated DC Voltage	6 – 12 \pm 0.1	VDC
RECOMMENDED OPERATING CONDITIONS		
Operating Conditions	Value	Units
Storage Temperature	68 (20) – 113 (45)	°F (°C)
Storage Humidity	60 \pm 25	% R.H./Non-Condensable
Ambient Temperature	32 (0) – 113 (45)	°F (°C)
Ambient Humidity	60 \pm 25	% R.H./Non-Condensable
Standard	Protection Type	
IEC standard 60529/ EN 60529	IP40 / Indoor use only	
OUTPUT RATINGS		
The system provides up to 5 control relay outputs.		
Parameter	Value	Units
Maximum Switching Current for Compressor and Defrost Relays	≤ 12	A
Maximum Switching Current for Other Relays	≤ 3	A
Maximum Switching Capacity	≤ 360	VA
Maximum Switching Voltage	≤ 240	VAC, 50/60 Hz
Inbuilt Alarm	An internal sound alarm is automatically triggered whenever any sensed temperature, current or voltage surpasses the limits set by the user, AC interruption is detected, or a digital input remains active for a considerable lapse. This output can be disabled through HMI.	
INPUT RATINGS		
Type	Note	
Analog Sensor	Since the controller is aimed for refrigerated systems, it is adapted to receive 3 typical 10k NTC Thermistors. This are automatically linearized and digitally filtered.	
Digital Input	A set of 2 dry contact inputs are available.	
Calibration	Comes calibrated from factory to receive the specified sensors. Field calibration can be easily performed with an external reference thermometer. Process variable offset is provided for modification, to correct sensor's errors.	



CONTROL CHARACTERISTICS

Parameter	Description
Control Method	ON/OFF
Setting Method	Digital setting using HMI options, or remote setting features
Indication Method	LED 4 digits Display. Touch. Full HD 4.3" Touch Screen WEB Monitoring Interface

SUPPORTED APPLICATIONS

Purpose	Range	Common Fields
Temperature monitoring and control	T: -40° (-40°F) to 50°C (122°F)	<ul style="list-style-type: none"> ✓ Freezers – Refrigerators. ✓ Cold rooms. ✓ Scientific refrigerators. ✓ Stability chambers. ✓ Incubators.

WIRELESS MODULE SPECS

Device Type	Standard	Note
NB031803-Wi-Fi	Wi-Fi (IEEE 802.11) 2.4 GHz. WPA2 encryption.	Stores configuration data for up to 3 networks.
NB031803-GPRS	GPRS. Quad Band: 850/ 900 /1800 /1900 MHz	Can be subscribed to any mobile phone operator.
NB031803-Sigfox	Sigfox Ready, RC2 902 – 905Mhz / RC4 920 - 923Mhz, 22dBm ERP	Zone 2 (USA, Mexico) and Zone 4 (Latin America).

DIMENSIONS

Main unit's dimensions

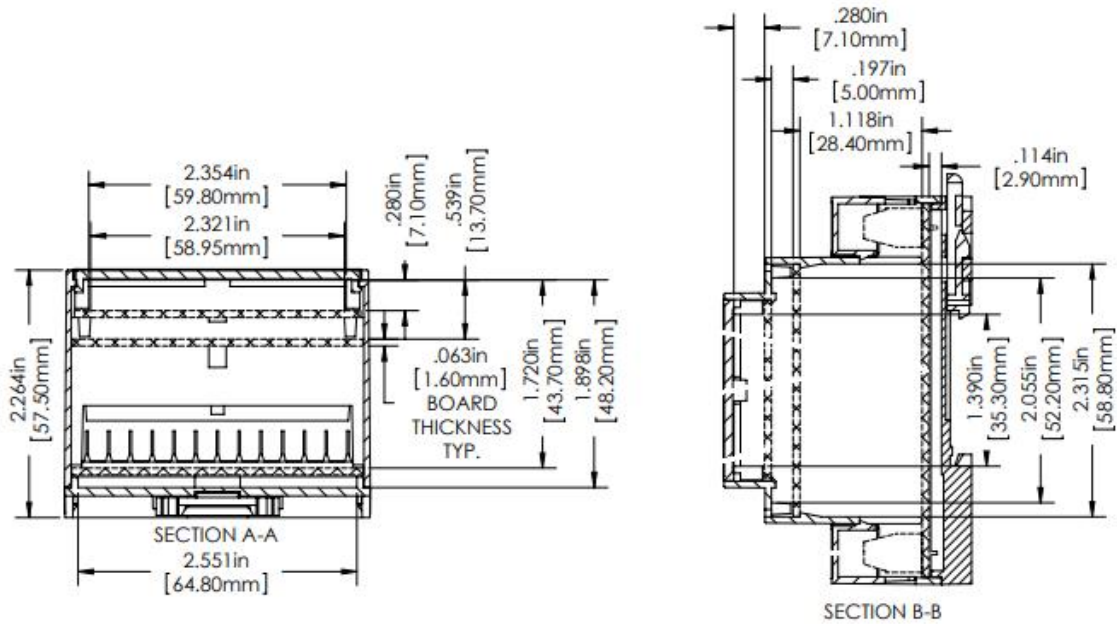

Material: PC/ABS (UL94V-0).

For further information concerning this enclosure, visit: [//goo.gl/MPVsww](http://goo.gl/MPVsww)

Weight: 80g, without accessories.

Display panel dimensions

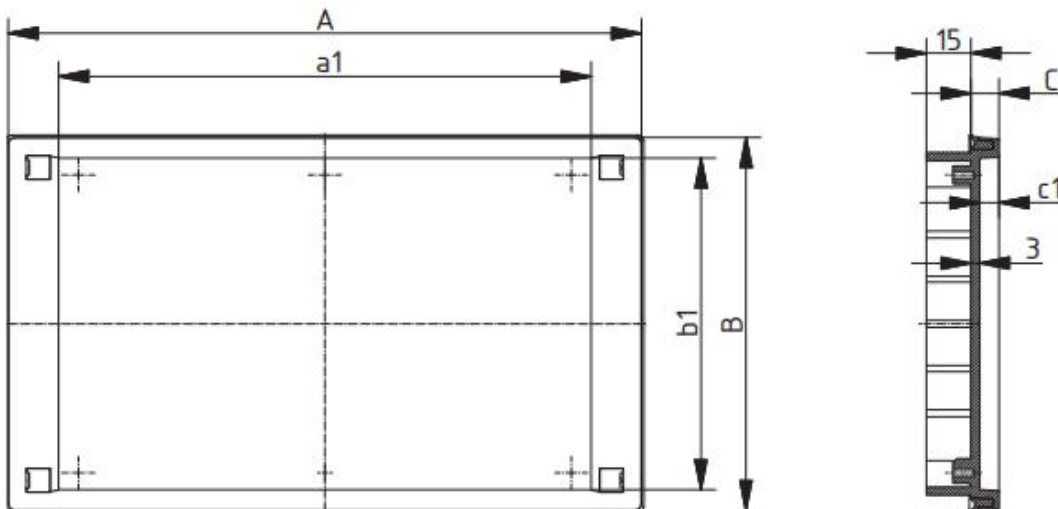

Material: ABS (IP54). A=166mm B=106mm C=9,5mm a1=131,3mm b1=92,3 c1=6,5. For further information concerning this enclosure, visit: [//goo.gl/hex7Y4](http://goo.gl/hex7Y4)

Weight: 100g, without accessories.

SENSOR'S TECHNICAL SPECIFICATIONS

NTC Temperature Sensor (P/N NBSE031801)

Parameter	Value / Type
Temperature Range	-40.0 °F (-40°C) to 122°F (50°C)
Resolution	0.1 °F (0.1°C), over whole range
Max. Error	1 °F (0.5°C), over whole range
Probe Type	Thermistor NTC 10K, Stainless steel probe, PVC 2m. cable

WEB PLATFORM AND SERVICES



Devices work in conjunction with Web platform and Web Platform® APP.

Users can access 3Sense platform, via WEB or APP, to perform:

- ✓ Remote monitoring and visualization of Temperature and R. Humidity records, in graphs and data tables, from up to 2 years.
- ✓ Alarm management for variables out of range, battery levels and AC power fails.
- ✓ Add comments to records.
- ✓ Set alarm limits, among other custom settings like sensors' names.
- ✓ Configure accounts' access and permits.
- ✓ Set alarm events such as e-mail or SMS notifications.

I/O RECOMMENDED PROFILE

